

**STUDENT PACK**

**B) STONE FLOOR**



# Beeleigh Mill Restoration Group (BMRG) - Education

## **Beeleigh Mill – the stone floor**

**Burr stones:** hard quartzite stones from France imbedded in plaster and held by metal bands.

**Chute:** a connecting tube, sometimes square, letting grain enter the hopper from the grain bin.

**Damsel:** this shakes the shoe which moves grain down inside the millstone.

**Flour:** result of milled grain with the outer skin (husk) removed.

**Hopper:** upside down pyramid box sitting on top of the horse

**Horse:** this sits on the tun and holds the shoe and hopper.

**Milling:** process of crushing and grinding to remove the grain husk into a powdered form.

**Shoe:** this wooden trough feeds grain into the millstone centre and is shaken by the damsel.

**Tenterring gear:** mechanism for raising or lowering stone gap to adjust the flour quality.

**Tun:** wooden surround which houses the millstones.

**Wheat:** grain milled to make flour.

# Beeleigh Mill - The Stone Floor

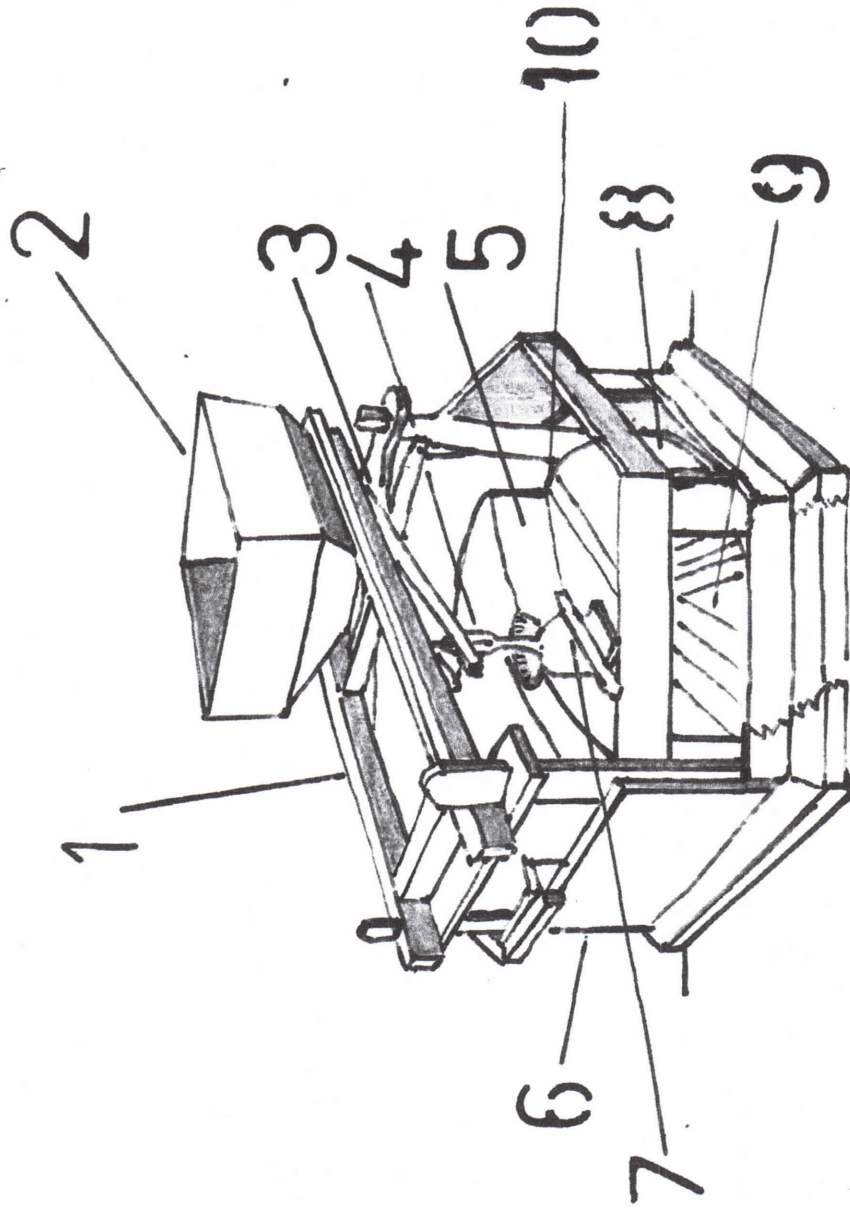

Put the correct number against the right description:

Bed Stone	Runner Stone	Tun	Damsel	Mace & Rind
Hopper	furrows	Shoe	Spindle	nip

# Beeleigh Mill-the stone floor (BMRG)

Making Flour

Z	V	U	H	J	F	Q	Z	H	G	M	T	S	B	E	G
E	W	T	H	O	N	Z	O	V	G	A	W	O	R	E	R
U	I	K	U	C	P	R	Z	V	Z	V	H	A	O	Q	S
H	M	K	Z	N	S	P	R	G	X	I	E	H	Z	D	B
A	S	G	A	E	F	G	E	Q	O	G	S	B	I	P	C
I	D	M	X	Y	L	Y	I	R	G	T	A	E	H	W	F
V	G	A	O	L	O	H	L	N	Y	G	O	Z	J	O	F
C	S	B	M	L	U	Q	I	F	B	H	K	G	N	Y	V
X	M	X	B	S	R	R	Q	K	X	W	N	H	H	W	A
W	I	C	E	R	E	N	V	C	T	I	B	A	I	Y	Q
K	Q	J	W	T	X	L	S	R	L	U	F	X	Z	I	P
I	R	V	N	O	U	V	A	L	Z	C	Z	I	G	A	G
R	D	E	E	G	D	H	I	X	T	U	F	D	N	N	R
Z	T	O	D	U	D	M	C	D	D	O	L	G	J	N	E
P	I	Y	Q	U	D	B	U	R	R	S	T	O	N	E	S
Y	R	B	Q	X	J	A	M	R	B	V	F	S	S	V	V

BURRSTONES

CHUTE

DAMSEL

FLOUR

HOPPER

HORSE

MILLING

SHOE

TENTERINGGEAR

TUN

WHEAT

## Beeleigh Mill- the stone floor

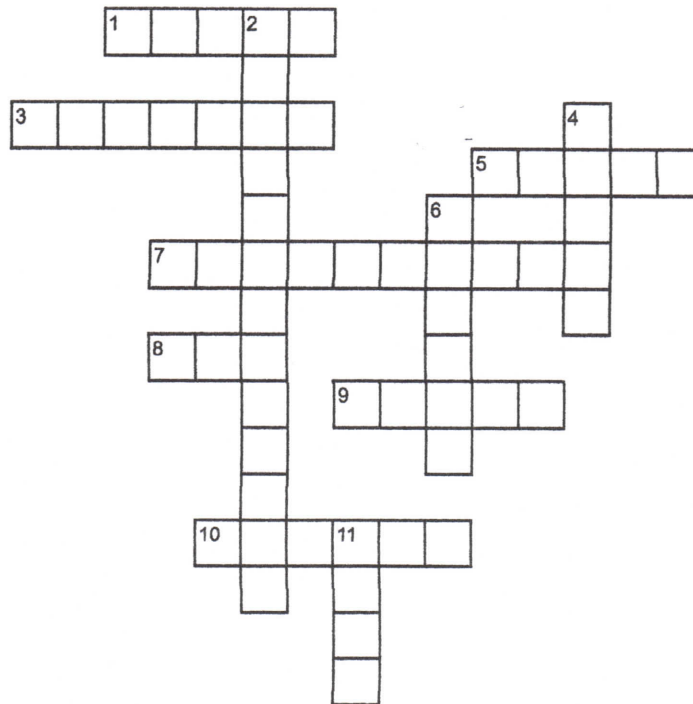

### Across

- 1 connects grain bin to the hopper
- 3 process of turning grain into flour
- 5 raw material for making bread after milling
- 7 special french stone bonded in plaster of paris
- 8 wooden casing around millstones
- 9 grain crushed and milled for flour
- 10 shakes the shoe so grain goes down into millstone

### Down

- 2 raises and lowers top of millstone for flour quality
- 4 sits on top of tun and holds hopper
- 6 sits on top of horse and controls grain to chute
- 11 a sloping trough which feeds grain into centre of millstones